

# K\_LUX tables

## La luce come materia

Più che un tavolino, K\_LUX è una presenza luminosa — una piccola architettura che cambia insieme allo spazio che la accoglie.

La sua identità risiede nella texture aperta: una trama in stampa 3D dove i fili di polimero disegnano vuoti calibrati, lasciando passare la luce, che si frammenta e si riflette. La superficie non è chiusa, ma permeabile — un equilibrio sottile tra pieni e aria che genera profondità e vibrazione.

La base è realizzata in Crystal, la versione traslucida del polimero lucido. Un "non colore" che non si impone, ma accoglie e trasforma ciò che lo circonda. La luce entra, si piega, riemerge, rendendo la struttura un corpo vivo.

Il dialogo si completa con il piano Luna — vetro martellato materico, dalla superficie vibrante e quasi lunare. È qui che nasce il colore: la luce attraversa il piano e si deposita sulla base, generando riflessi e sfumature sempre diverse.

Il risultato è un oggetto che si comporta come un gioiello: mai uguale a sé stesso, mai statico. K\_LUX non ha un colore proprio — lo accoglie, lo rifrange e lo restituisce allo spazio in continue variazioni. Un tavolino che non si limita a sostenere, ma illumina

## Light as material

More than a side table, K\_LUX is a luminous presence — a small architecture that changes together with the space around it.

Its identity lies in the open texture: a 3D-printed pattern where polymer strands create calibrated openings, allowing light to pass through, fragment, and reflect. The surface is not closed, but permeable — a balance between solid and void that generates depth and vibration.

The base is made in Crystal, the translucent version of the glossy polymer. A "non-color" that does not impose itself, but absorbs and transforms its surroundings. Light enters, bends, and re-emerges, turning the structure into a living body.

The dialogue is completed by the Luna top — textured hammered glass with a vibrant, almost lunar surface. Here, color comes to life: light passes through the top and settles onto the base, creating ever-changing reflections and shades.

The result is an object that behaves like a jewel: never identical to itself, never static. K\_LUX has no color of its own — it absorbs, refracts, and returns it to the space in continuous variations. A side table that does not simply support, but illuminates.



# K\_LUX tables

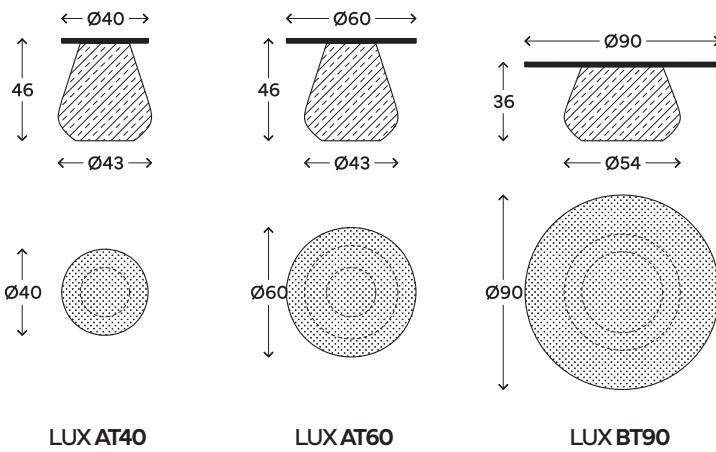

LUX AT40

LUX AT60

LUX BT90



## Luna

Vetro Martellato Verniciato Coprente  
Back Painted Hammered Glass

## Top

### Luna

Vetro Materico Verniciato Trasparente  
Transparent Painted Textured Glass

Ambra



Olive

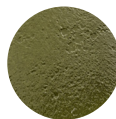

Ocean

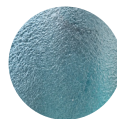

Red



Coffee



Anthracite



## Base

Crystal

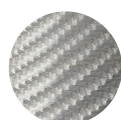

Polimero Trasparente  
Glossy Clear Polymer

**koèsia**

Via Majorana, 10A  
35010 Cadoneghe PD  
Italia

koesia.it  
+39 049 7359630  
info@koesia.it